



**Key Features:**

- **Versatile Condenser Microphone, Ideal for Both Vocals and Instruments**
- **Cardioid Polar Pattern with Excellent Feedback Rejection and Acoustic Isolation**
- **Multistage Pop Filter Eliminates Breath Pop Noises**
- **Memraflex™ Hardened Grille Screen**
- **Warm-Grip™ Handle for More Comfortable Feel**



**General Description:**

The Electro-Voice® RE410 is a professional quality handheld condenser microphone that was designed specifically for vocalists, yet has the versatility, smooth response, and dynamic range to make it outstanding for virtually any application. The RE410 is the ideal vocal microphone for anyone that appreciates the crisp high end and warm proximity effect that can only come from a top performing condenser microphone. The response of the RE410 is tailored to provide just a slight amount of “air” in the 5 to 10kHz area, enhancing the sound without adding stridency. The RE410 features a cardioid polar pattern that provides great rear rejection and a smooth off-axis response that’s perfect for performers who tend to “wander” around the mic.

**Application Notes:**

The low frequency response of the RE410 microphone varies with the distance from the sound source. Known as “proximity effect,” maximum bass response is produced in “close-up” use with the microphone 1/4 inch from the sound source. Normal bass response is experienced with working distances greater than 24 inches. Working close to the microphone will produce a more robust sound. Close up positioning of the microphone will also reduce the potential for feedback from the sound reinforcement system. When close-talked, the bass-boost provides an increase in overall microphone output level. The mixer gain may be proportionately reduced, resulting in a reduction of the system’s sensitivity to feedback caused by sound entering the microphone from the loudspeakers.

**Technical Specifications:**

Generation Element:	Self-Biased condenser
Frequency Response:	50 Hz to 20,000 Hz (see chart)
Polar Pattern:	Cardioid (see chart)
Sensitivity, Open Circuit Voltage, 1 kHz:	4.0mV/Pascal
Clipping Level (1% THD):	>140 dB SPL
Self Noise:	26 dB SPL “A” weighted (0 dB=20 micropascals)
Dynamic Range:	>114 dB
Signal-to-Noise Ratio:	68 dB (@ 94 dB SPL)
Output Impedance, 1 kHz:	250 ohms
Power Requirements:	Phantom Supply Requirement: 24 to 48 VDC
Polarity:	Positive pressure on diaphragm produces positive voltage on pin 2 relative to pin 3
Dimensions:	Length = 7.15" (182 mm) Diameter = 2.0" (51 mm) Shank = 1.1" (28 mm)
Accessories Furnished:	Stand Adaptor (Black) Soft Zippered "Gig" Bag
Net Weight:	9.2 oz. (260 grams)

## Frequency Response:

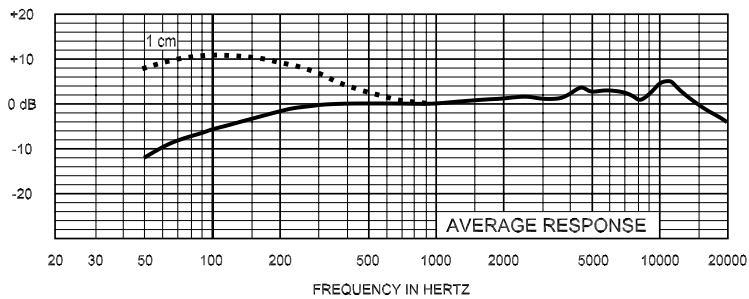

## Polar Response:

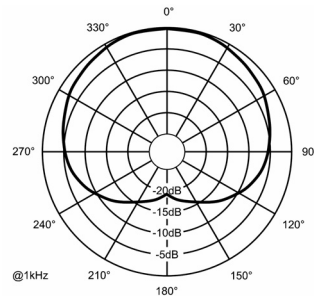

## Microphone Use and Placement

Please note that micing techniques are a matter of personal preference. These are merely guidelines to assist in the placement of the microphone to gain optimal performance.

### Usage

#### Vocals

#### Spoken Word

### Optimal Placement

Zero to six inches from the windscreen, and on axis with the microphone.

Five to ten inches from the windscreen, and on axis with the microphone.

## Standard Placement & Use Guidelines

1. Always point the microphone at the desired source of sound, and away from any unwanted sources.
2. The microphone should be located close to the sound source to minimize interference from other potential sound sources.
3. Use the 3-to-1 rule when using multiple microphones. Place each microphone three times farther from other microphones as from the desired sound source.
4. Minimize over-handling of the microphone to reduce unwanted mechanical noise.
5. Working close to the microphone will increase the bass tone and also provide increased gain-before-feedback.

## Dimension Drawing:

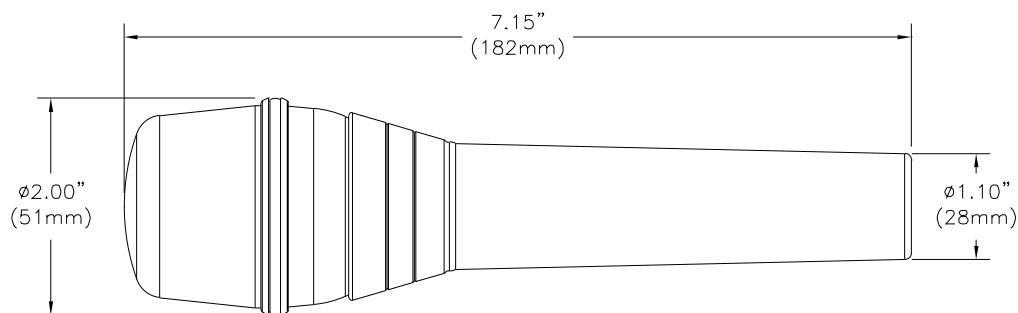

**RE410 Part Number: 301548-000**



12000 Portland Avenue South, Burnsville, MN 55337  
Phone: 952/884-4051, Fax: 952/884-0043

[www.electrovoice.com](http://www.electrovoice.com)

© Telex Communications, Inc. 7/2004  
Part Number 38110-328 Rev B

U.S.A. and Canada only. For customer orders, contact Customer Service at:

800/392-3497 Fax: 800/955-6831

Europe, Africa, and Middle East only. For customer orders, contact Customer Service at:

+ 49 9421-706 0 Fax: + 49 9421-706 265

Other International locations. For customer orders, contact Customer Service at:

+ 1 952 884-4051 Fax: + 1 952 736-4212

For warranty repair or service information, contact the Service Repair department at:

800/553-5992 or 402/467-5321

For technical assistance, contact Technical Support at: 800/392-3497 or 952/736-4656

Specifications subject to change without notice.