



DNH^{AS}

**N-3770 Kragerø
NORWAY**
 Phone: (47) 35 98 56 00
 Fax: (47) 35 98 56 10
 E-mail: dnh@dnh.no
 Web-site: www.dnh.no

**DNH WW Ltd.
England**

Phone:.....(44) 1908 275 000
 Fax:.....(44) 1908 275 100
 E-mail:.....dnh@dnh.co.uk

**DNH GmbH
Germany**

Phone:.....(49) 040 6569 30-0
 Fax:.....(49) 040 6569 30-30
 E-mail:.....dnh@dnh.de

Phone:.....(33) 1 5380 0276
 Fax:.....(33) 1 4588 1594
 E-mail:.....etienne@dnh.no

**DNH
Speakers Inc.
USA**

Phone:.....(1) 484 494 5790
 Fax:.....(1) 484 494 5793
 E-mail:.....dnh@dnhspeakers.com

ISO 9001 CERTIFIED

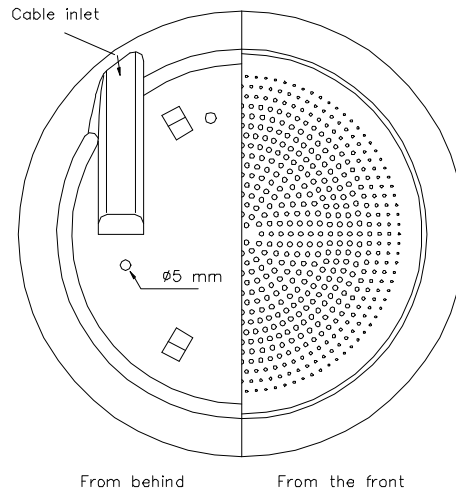
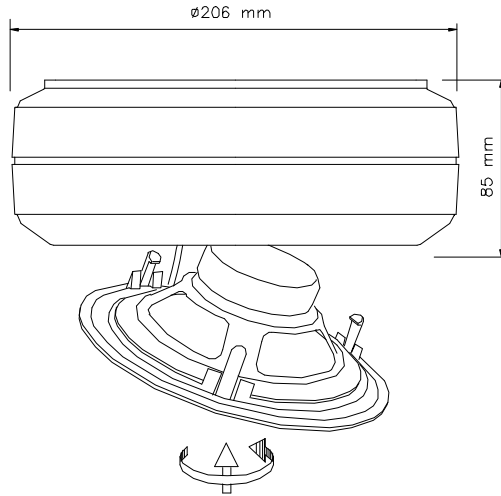

Transformer:
 Combined
 70/100Volt line
 White : Red 100 V
 White : Green 70 V

Secondary nominal
 tapings:
 C : 6W 6,0 W
 C : 3W 3,0 W
 C : 1,5W 1,5 W
 C : 0,5W 0.5 W

Sound pressure levels at different frequencies at 1W/1m
 1/3 octave pink noise.

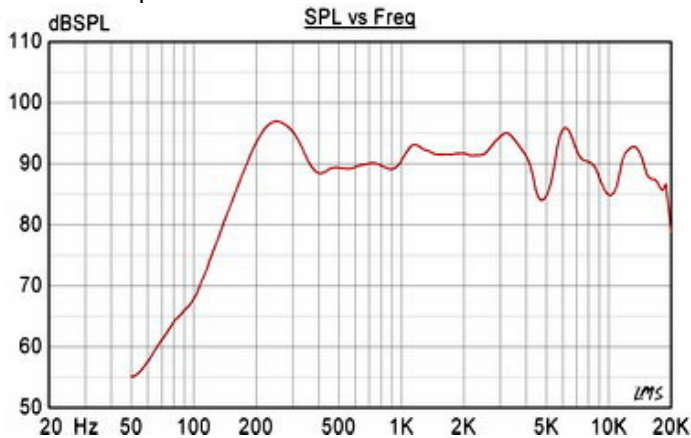

Material / Color ABS / RAL 9010
 Mounting Screws (max ø5mm)
 Termination Spring clamp
 Weight 1,4 kg
 IP-rating
 Max. / min. amb. temp 90°C / -20°C
 Rated / max. power 6 W / 15 W
 SPL 1W/1m 90 dB
 SPL rated power 95 dB
 Effective freq. range 130 – 12000 Hz
 Dispersion (-6dB) 1kHz / 4kHz 150° / 50°
 Options Impedance, color, label

Installation, Operation and Maintenance Procedures

- When mounting the loudspeaker please ensure that it is re-assembled in the same manner in which it was received.
- Screw the cabinet to wall or ceiling, connect cable to terminal and screw the loudspeaker grill clockwise into fixed position.
- For optimum performance, always use the correct voltage / power and operate within the frequency limits as stated.
- BLC-550CR(T) is designed for clean room applications.
- Do not open loudspeaker when energized.
- This loudspeaker is supplied with a 2 year warranty against defective workmanship.

